



*Great Dane*

A Division of Great Dane Limited Partnership  
[www.greatdanetrailers.com](http://www.greatdanetrailers.com)

*Great Dane*

SSL FREIGHT VANS



# SSL FREIGHT VANS

THE SSL DRY FREIGHT VAN FEATURES A HIGHER CUBIC CAPACITY COMPARABLE TO PLATE AND COMPOSITE WALL TRAILERS, BUT WITH UNMATCHED DURABILITY.

**THE SSL IS DESIGNED WITH PROVEN SHEET AND POST CONSTRUCTION. SIDEWALL REPAIRS REQUIRE NO SPECIAL TOOLING, UNFAMILIAR PROCEDURES OR ADDITIONAL PERSONNEL. REPLACED COMPONENTS CAN BE SOLD FOR SCRAP AND RECYCLED.**



## REAR CONSTRUCTION

The rear frame is made of high-strength, tubular steel. The buckplate is a formed tube with a continuously welded .38" bottom plate. The bottom plate and 1" thick steel bumper guards provide rear impact and hinge protection. The bottom rear side marker lights are recessed. A 3" beveled steel cap angle covers the floor to prevent damage at the end of the floor. Threshold plates are available as an option. ♦ Lock rods are galvanized steel. The SSL 100" comes standard with two lock rods; the SSL 101" comes standard with four lock rods. An additional anti-theft feature, the Secura-Cam allows the lock rod to be secured with a padlock directly to the lower keeper. Secura-Cam is standard on the curbside door. Four heavy-duty extruded aluminum hinges per door are standard. Anti-theft fasteners are at top and bottom hinges on each door.

## PLYMETAL DOORS

Great Dane's Tri-Seal gasket, with three functional seal surfaces, maximizes protection against moisture intrusion. The two auxiliary inner gasket surfaces seal out moisture, even if the outer gasket is damaged. The perimeter molding (PVC) is integral with the gasket.

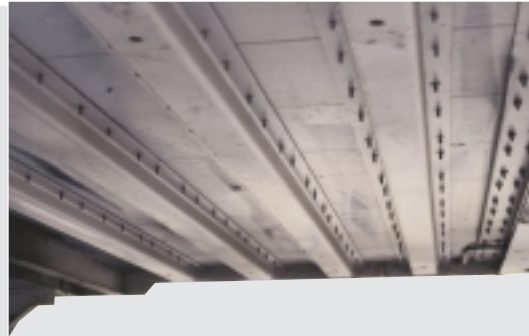

### UPPER CONSTRUCTION

Full-width steel gutter diverts water to the eaves and further reinforces the shallow rear header. The shallow rear header is reinforced at the corners by massive steel gussets, both top and side, which minimize racking and ensure the frame remains square throughout the life of the trailer. The rear header is recessed to prevent snagging. An additional logistic post is conveniently located just ahead of the rear door to secure cargo at the extreme rear of the trailer.

### LANDING GEAR

Great Dane's Model 60 landing gear features heavy-duty "K" bracing which provides superior leg support. Shock-mounted sand shoes, with replaceable pads, reduce vertical forces in the crossmembers and bottom rails up to 50%. The bolt-on bracing eliminates the need to reweld crossmembers in repair situations.

### LOWER CONSTRUCTION

The rear impact guard is made of fabricated steel and exceeds all federal requirements. A recessed area for the conspicuity tape protects the tape from abrasion. The stop, tail and turn lights are shock mounted and recessed. A .50" steel flat bar provides protection around and between the lights. The backside of the lights are enclosed in and protected by the tubular buckplate.

### CROSSMEMBERS

Steel hat-section crossmembers installed between the upper coupler and landing gear provide an anti-sag transition area behind the king pin. Lock nuts secure the bolts through the floor to the upper coupler connection. A.A.R. certified king pin is standard.

GREAT DANE  
**SSL**



## SSL DRY FREIGHT VAN

The Great Dane SSL sets the standard for strength and durability. It's distinction is the unique construction of its interior lining — single sided laminate. An interior panel far superior to that of plywood or plastic linings. The SSL design possesses all of the advantages of conventional sheet and post construction — including ease of repair. Available in two interior widths, 100" and 101", the Great Dane SSL provides more cubic capacity than standard dry freight vans.







## INTERIOR LINING SINGLE SIDED LAMINATE

The SSL's distinction is the durable construction of the interior lining. A layer of .019" steel over a rigid core produces an interior panel far superior to plywood or plastic linings. The steel layer wraps the edges of the core to create an anti-snap surface. A rigid core bonded to steel ply assures the interior will not wrinkle or easily crumple from repeated forklift impact. ♦ The puncture strength of the SSL lining is nearly six times greater than .25" domestic plywood and over four times greater than MDPE plastic. The coating of the SSL lining is standard in a natural gray finish and optional in a white finish.

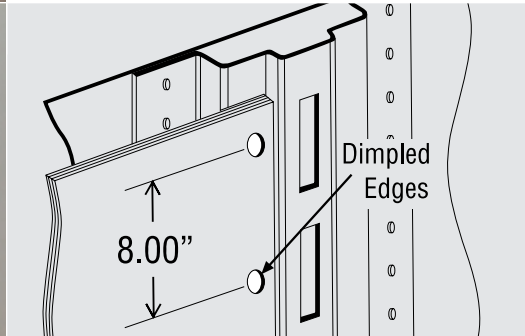
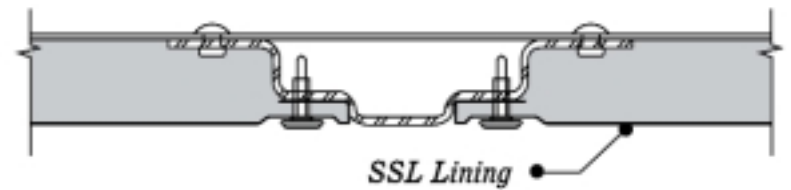

### CUFFBANDS

standard galvanized, roll-formed steel scuffband one-piece and installed the full length of the aisle. Other materials such as laminated hardwood, extruded aluminum, steel or a space-age composite are available as an option. Great Dane's L 100" has scuffbands available in a variety of heights and can also be installed across the front all. Great Dane's SSL 101" has a nominal 12" recessed scuffband available in steel only.

### LOGISTIC POSTS

The SSL 100" has slotted A-punched logistic posts located on 24" centers full length. Shallower intermediate uprights are located between the logistic uprights over the landing gear and forward to produce 12" centers. The intermediate hat-section uprights are located behind the SSL panels. The SSL 101" has slotted A-punched logistic posts on 12" centers at front and 24" centers at rear. The posts are roll-formed from heavy 14-gauge galvanized steel. Logistic post slots are on 4" vertical centers.

### RECESSED FASTENERS

The edges of the SSL panels are dimpled at 8" intervals to provide a coined surface for each fastener head. The heads of each screw used to attach the lining to the upright are flush, which means no protruding heads to snag valuable freight. A unique automation process used to coin the edges assures the fasteners will be consistently located in each SSL panel.

### FLOORING

Floorboards of 1.38" laminated hardwood are pre-undercoated and designed with a crusher bead joint to ensure a uniform and secure seal between the floorboards. Wax-coated I-beam crossmembers are 3.45 lbs. per foot.

## SQUARE INTERIOR CORNERS TOP RAILS ARE EXTRUDED SPECIFICALLY TO TAKE ADVANTAGE OF THE CARGO CARRYING CAPACITY.

The top rail creates a square corner in the upper sidewall without protruding into the cargo area. Cargo fits against the walls from floor to ceiling.

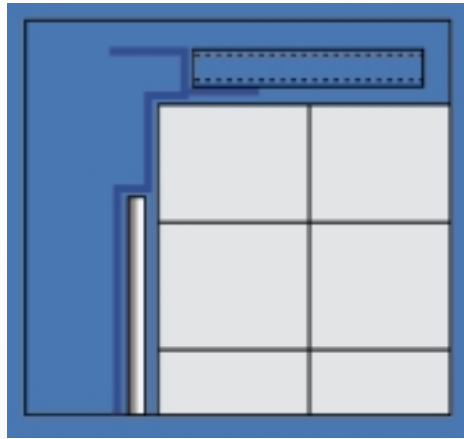

### FRONT CORNER CONSTRUCTION

The front corner of the SSL 101' is constructed with a 3" radius to allow for a square interior with the thinner sidewalls. A durable aluminum casting shields the front top corners, lessening the need for repairs from limb impact damage. The flat surface of the casting allows recessed mounting of the front top lamp.

The front corner of the SSL 100' is a standard 6" radius with .050" aluminum corner sheets.

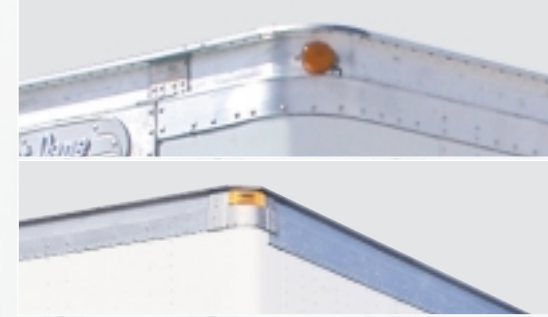

### ROOF BOWS

Galvanized steel, anti-sag roof bows are on 24" centers and are permanently bonded to a one-piece aluminum or fiberglass roof sheet. The roof sheet is closely riveted with a foam sealing tape to the top rail. Both the roof sheet and the top rail are secured by an aluminum "J" molding. Then a liberal coating of neoprene sealant is applied that evenly coats the rivet heads.



### FRONT END STRENGTH

Exceptional front end strength is provided by four 2.5" deep hat-section steel posts with .050" flat aluminum front panels riveted to the posts on 2" centers at the sheet laps. An extruded aluminum impact plate extends across the bottom front and around the corners to side rails. Combined with a rolled lip, the front of the upper coupler is protected from fifth wheel impact. The aluminum impact plate eliminates the potential for rust.



MIRROR FINISH STAINLESS STEEL FRONT  
AND CORNER PANELS ARE AVAILABLE.

